

सीएनसीमशीनोंकेलिएज्ञानकेंद्र

KNOWLEDGE CENTRE FOR CNC MACHINES

PROGRAMMERS GUIDE FOR CNC MACHINES



INDEX

SN	Topic	Page No.
1	Introduction to NC/CNC machines and Part Programming	03-06
2	Programming Modes	07-09
3	PREPARATORY (G) FUNCTIONS ISO 646	10
4	MISCELLANEOUS (M) FUNCTION ISO 646	11
5	MISCELLANEOUS & CODES & ADDRESSES FOR LATHE MACHINES	12-13
6	SAMPLE PROGRAMS FOR CNC TURNING MACHINES	14-33

NC / C N C

- **Numerical Control (NC)** is a method for control of slide motions and auxiliary motions of machine tools in **form of numerical** data.
- **Computer Numerical Control (CNC)** is Microprocessor based system to **store and process data** for control of slide motions and auxiliary motions of machine tools.
- Development of computer numerically controlled Machine is outstanding contribution to Manufacturing industry
- It has made possible automation of machinery processes with flexibility to handle as small and medium batch quantities in part production.

Functions of CNC Machines

- ❖ One or more machine axes slide movements controlled either single of simultaneously.
- ❖ Control of feed rate along slide ways and its direction.
- ❖ Control of spindle rotational speeds (step-less constant surface speed)
- ❖ Start/Stop of main spindle rotation and change of direction.
- ❖ Control of coolant, ON/OFF.
- ❖ Control of tool change, turret head indexing, tool selection, loading of selected tool from automatic tool changer etc.
- ❖ Control of numerous other functions e.g. tool wear/breakage monitoring function, pallet changing, robot loading functions. Also other function related to operator and/or machine safety system. Software and limit switch boundaries, chuck guard locks, overload monitoring.

Advantages of CNC Technology:

- ❖ Due to its flexibility, the machine utilization is very high.
- ❖ The lead time is very largely reduced thereby prediction of the delivery schedule is more reliable.
- ❖ Need of special purpose tooling, jigs and fixtures is mostly eliminated.
- ❖ Consistency in quality is assured since the manufacture is automatic. This indirectly reduces the inspection costs.
- ❖ Handling time is very largely reduced since most of the operations can be carried out in minimum number of set ups. With facility of automatic tool changing, pallet change and clamping and unclamping arrangements, the non-machining time is eliminated to maximum extent.

- ❖ Since a single machining center can perform many operations, large floor area is saved which otherwise would be required to install a number of conventional machines.
- ❖ Since the input instruction can be easily modified, design changes in the products can easily be incorporated. This is very advantageous in prototype manufacture or in manufacture of similar parts in small batch size.
- ❖ Operator's skill is no longer important since the accuracy is dependent on the program. This reduces scrap and rework.
- ❖ Sudden change in demand can be easily handled because the system has in built flexibility.
- ❖ Work in progress, handling time and errors due to a number of set ups, as in conventional manufacture, are reduced to a very large extent when machining centers are used.
- ❖ Since mostly all conditions are under control, the estimation of costs involved can be done quite accurately.

Disadvantages of CNC Technology:

- ❖ NC essentially calls for very high investment. But this should be carefully considered in the light of numerous advantages and over a period of time.
- ❖ Special skills in programming and maintenance are essential.
- ❖ Redundancy in labour may be there. But this again needs careful consideration. When planning for NC, retraining of staff for newer requirements must be taken into account.
- ❖ Down time of NC systems is very expensive, therefore, it is very essential that that staff is adequately trained in operation and maintenance at the supplier's place before the machine is delivered.

Part Programming

The preparation of a set of instructions to carry out the machining of a work piece is called part programming. This work is carried out by a part programmer. He prepares the planning sheet and writes the instructions in a coded form which is acceptable to the controller of machine tool. Part programming is of two types:-

- Manual
- Computer assisted

In the former, the programmer prepares the program and uses the tele type to prepare the punched tape version of the program. In the later, the tape is produced by the computer after it has been fed simple instructions in proper format which are different from the one used in manual part programming. Various symbols used in programming are given below.

- N : Operation sequence number address
- B : Preparatory function address
- X, Y, Z, A, B, C : Dimension address with axis Identification.
- S : Spindle speed address
- G : Feed rate address
- T : Tool address
- M : Miscellaneous function address.

What the programmer has to do?

1. Study the relevant component drawing thoroughly
2. Identify the type of material to be machined.
3. Determine the specification and function of machine to be used.
4. Decide the dimension and more-metric or inch.
5. Decide the coordinate system –absolute or incremental.
6. Identify the plane of cutting.
7. Determine the cutting parameter for the job/tool combination.
8. Decide the feed rate programming – mm/min or mm/rev.
9. Check the tooling required.
10. Establish the Sequence of machining operations.
11. Identify whether use the special features like subroutines, mirror imaging, etc. is required or not.
12. Decide the mode of storing the part of program once it is completed.

Structure of a Part Program:

A part program defines a sequence of NC machining operations. The information contained in the program can be dimensional or non-dimensional like speed, feed, auxiliary function etc. The basic unit of part program input to the control is called a block. Each block contains adequate information for the machine to perform a movement and / or functions. Blocks in turn are made up of words. Each word consists of number of characters. All blocks are terminated by the block end character.

A block may contain any or all the following:

- Sequence or block number (N)
- Preparatory functions (G)
- Dimensional information (X, Y, Z etc.)
- Decimal point (.)
- Feed rate (F)

- Spindle speed (S)
- Tool No. (T)
- Tool offset function (D)
- Miscellaneous functions (M, H etc.)
- End of block (EOB).

Block Example

N1234 G.. X.. Y.. S.. M.. F.. T.. D.. LF

The Word Addressed system is method generally use for writing part program for the numerical control of the wide range of machines. In this system there is an identifying letter (alpha character) preceding each data? This alpha character in the world is known as the address, e.g. G2, N2, etc. A control unit recognizes a word through its address. A number of the word makes up a block and two blocks are separated by a marker. Generally, the words need not be programmed in a particular order. Different word may have a different number of digits; some have only one digits and other may have up to seven digits. Whenever a word represents machine movement data, a + or a- may be required between the latter and the number

Example of a Block

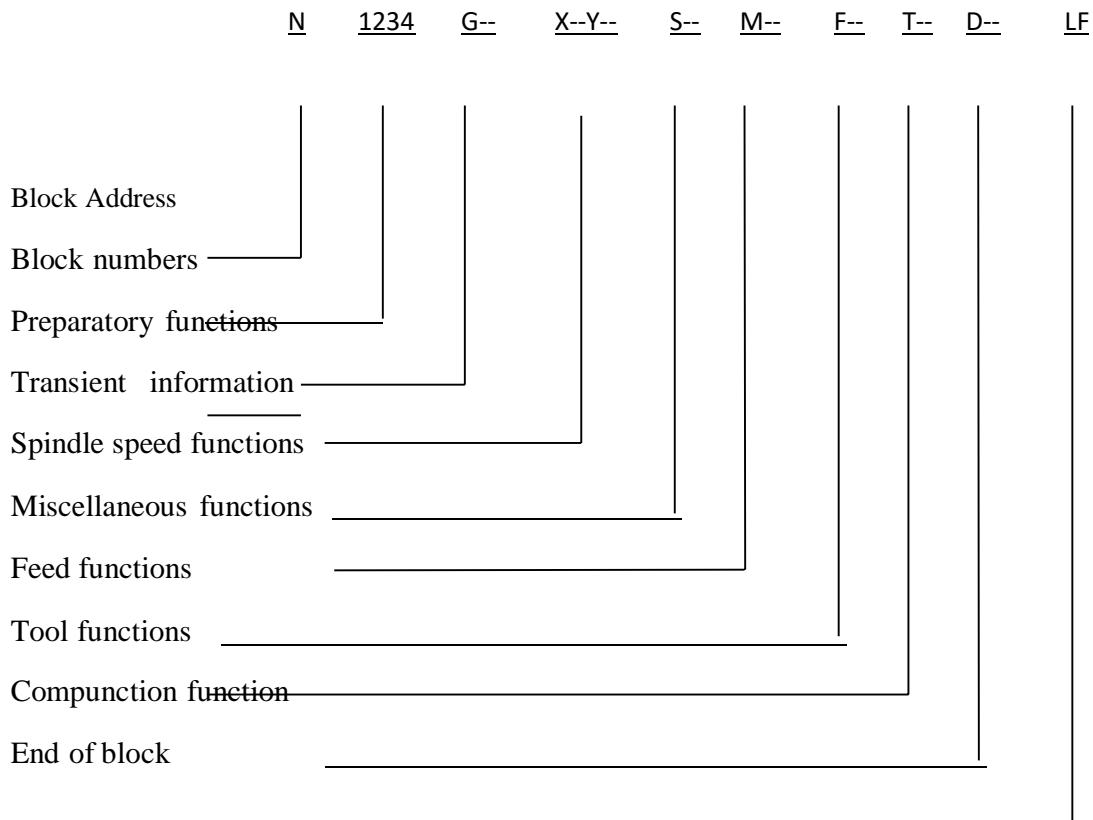

Programming Modes

To prepare the manuscript for manual part programming, the programmer needs to collect some data pertaining to the work to be carried out.

The data would be follows:-

- Specification of Machine
- Specification of all tools.
- Specification of work material.
- Speed, feed tables etc.

There are two modes of programming in CNC systems

- Absolute mode
- Incremental mode
- **Absolute Mode:**

Movement is programmed as the complete distance from a specified point, say the start point or the zero point.

- **Incremental Mode:**

In this mode the movement of the tool, slide or table is described or programmed as the distance from the end point of the previous mode and must be given the appropriate negative or positive sign.

- **Diameter and radius program**

Some machines are designed to be programmed in diameter or radius mode. Programming for diameter is done by input of data in **diameter mode**. The values are provided for diameter at different locations as per component deg. The programming for radius is done by input of data in **radius mode** and the values are provided for radius at different locations.

Understanding Program Zero:

Every CNC machine has a reference or machine zero. This is a position that is a constant to the machine. When a machine is first turned on or powered up by an operator it must be referenced before any programs can be executed. This is a process that moves the machine to the zero point on all its axes. These points are

set by mechanical limit switches. When the machine reaches these limit switches the control registers this location as home. This home position is kept by the control until you turn the power off. Using the home position as a reference you can now tell the control where on the table you expect it to find the piece to be worked on. To determine this second work reference point you should first understand how a CNC machine interprets its direction of movement. All machining centers move on one or more axes. Assuming the machine is vertically configured; one with the head directly above the table, the standard set of axes is:

- X (left and right)
- Y (forward and back)
- Z (up and down)

Each axis has two possible directions in which it can travel: + (plus) and - (minus). This is referred to as the Cartesian coordinate system. The Cartesian coordinate system can be defined as two or three mutually perpendicular axes which intersect at a common point called the origin.

Types of motions:

Every CNC machining center has only two types of motion.

- Linear
- Circular

Linear motion is just as it sounds; straight line movement. These moves can be in any direction and can include all three axes. A linear move must be performed in one of two modes. Rapid or feed rate. Which mode the motion is executed is determined by a preparatory G code. G0 initiates a rapid movement and G1 is interpreted as a movement at a specified feed rate.

Rapid Linear Motion Example G0 G91 X2.0 Y2.0 Z-2.0

Feed Rate Linear Motion Example G1 F25. G91 X2.0 Y2.0 Z-2.0

The second motion type is circular. A circular motion, in contrast to a linear motion, can only be performed at a specified feed rate. A circular motion can be a full circle or it can be just a small segment of an arc. There are two event G codes used to initiate a circular motion. G2 and G3. The first, G2 tells the control that the following data should be used to create an arc in the clockwise direction. , G3 is counterclockwise.

Clockwise Circular Motion Example

G2 X0 Y0 R2.0

G3 X0 Y0 R2.0

Graphical Simulation

It is advisable to verify all programs in memory using the tool path simulation facility. This will display immediately, any dimensional program errors by displaying the bar stock being machined step by step on the VDU.

COMMON CODES & ADDRESSES PREPARATORY (G) FUNCTIONS ISO 646

G01	Positioning at rapid traverse
G 01	Linear interpolation
G 02	Circular Interpolation, clockwise
G 03	Circular Interpolation, counter clockwise
G 04	Programmable dwell
G 06	Parabolic interpolation
G 08	Automatic acceleration to a known speed
G 09	Automatic de-acceleration to a known speed
G 17	Selection of circular interpolation in the XY plane, for compensation of rotating
G 18	As above, for ZX plane
G 19	As Above, for YZ plane
G 33	Thread turning constant pitch
G 34	Thread turning increasing pitch
G 35	Thread turning decreasing pitch
G 40	Cancellation of tool compensation
G 41	Rotating tool compensation, right hand side
G 42	Rotating tool compensation, left hand side
G 43	Tool positive compensation move.
G 44	Tool negative compensation move.
G 53	Cancellation of zero point shift
G 54-G60	Zero point shift codes
G 63	Threading by tap
G 70	Programming in inches
G 71	Metric unit programming
G 74	Move to start point
G 80	Cancellation of canned cycle
G 81-G 89	Reserved for canned cycles
G 90	Absolute programming mode
G 91	Incremental programming mode
G 92	Data input to memory in advance
G 93	Feeders value is translated proportional to time
G 94	Feed in mm/min.
G 95	Feed in mm/spindle revolution
G 96	Constant peripheral speed
G 97	Spindle revolutions/min.

MISCELLANEOUS (M) FUNCTION ISO 646

M 00	Program stop
M 01	Intermediate stop
M 02	Program end
M 03	Spindle rotation clock wise
M 04	Spindle rotation counter clock wise
M 05	Spindle off: coolant off
M 06	Tool change
M 07	Coolant No. 1 on (e.g. Mist coolant)
M 08	Coolant No. 2 on (e.g. flood coolant)
M 09	Coolant
M 10	Clamping (e.g. tables, slide, work piece, fixture, spindle etc)
M 11	Clamping released
M12	Free 1)
M 19	Spindle stop in specified angular orientation
M 20-M29	Continuous free 2)
M 30	Program end, stop and return to start character
M 31	Clamping override
M32-M39	Free 1)
M40-M45	Change of gear ratio if this required. Otherwise free 1)
M46-M47	Free 1)
M48	Cancels M 49
M 49	Deletion of manually adjusted feed rate or rotation speed, i.e. return to programmed values
M50-M57	Free 1)
M 58	Cancels M 59
M 59	Maintains the spindle speed constant even though a G 36 initiated (const. surface speed)
M 60	Work piece change

Lay out of new turning program

1	Part program	Program manager —part program---New(File Name)--ok
2	Work piece	Select Various – Blank —(Input of work piece) --Accept
3	Starting Program	Enter –(Starting Program)
4	Contour cal(Cycle 62)	Select Cont. Turn. -Contour –contour cal—(name of sub program) Accept
5	Stock Removal(cycle952)	Select Back -Stock Removal (M/C control of program)-Accept
6	End program	Enter-(end program)
7	Sub program	E_LAB_A_(Name of sub program): -enter (sub program or turning tool path from 1 st point to end point of job)
8	Numbering	Numbering select(10 or 2) OK
9	simulation	Reset-simulation-edit
10	Tool offset	MDA ---MDI, G75x0z0,M06 T01D1 M30—(Feed 0 check)-cycle start(Go to home position)-- Jog Mode-- measuring tool—manually- touch tool on z axis- -z 0 –Input --set length-save position-- touch tool on x axis- X25 (job diameter)—input-- set length-- save position
11	Execute	Select Program – execute –(check feed switch 0 position)-- auto mode - cycle start ---Feed increase by manually feed switch

DEFINATION OF SHORT KEYS

JOG	Manual machine movement by feed switch in x or z axis with +or- button
MDA	Manual machine movement by G or M Code in x or z axis - MDA mode (machine data input ---MDI, G75x0z0, M30 - cycle start(Go to home position)--
AUTO	Program auto start for execute
RESET	Machine reset start from beginning
SBK	Check program in Single block check
MPG	Manual pulls generate MPG-VAR-Select plus co-ordinate-Use hand wheel for x or z axis
WCS	Work coordinate system
MCS	Machine coordinate system

TYPES OF CNC PROGRAM SYSTEM

1	FANUC -- {SIMPLE OLD FUNCTIONE}
2	SIEMENS-- {GOOD FOR BOTH PURPOSE}
3	HAAS-- {GOOD FOR LEARNING AND PROGRAMING}
4	MAZAK-- {ADVANCE TECHANOLGY}
5	HEIDENHIEN-- {CYCLE SYSTEM EASY FOR USING}

CODES & ADDRESSES FOR LATHE MACHINES

<u>M CODE - DESCRIPTION</u>	<u>G CODE- DESCRIPTION</u>
M00 Program stop	G00 Rapid or idle tool path/motion
M01 Optional stop	G01 Linear or cutting tool path /motion
M02 program end	G02 CW circular tool path/motion
M03 spindle CW	G03 CCW circular tool path/motion
M04 Spindle CCW	G04 Dwell time/waiting time between two
M05 spindle stop	Function
M06 ATC/ Auto Tool change	G70 Inches unit input
M07 flush coolant ON	G71 Metric unit input
M08 Coolant ON	G75 Homing position point
M09 Coolant off	G90 Absolute mode
M10 Chuck / vice unclamp	G91 Incremental mode
M11 Chuck / Vice clamp	G94 Feed/minute
M17 Sub program continue	G95 Feed/Revolution
M18 Height tool offset call	G96 constant cutting speed ON
M20 Arm IN	G97 constant cutting speed Off
M21 Arm out	
M24 Tool clamp	
M25 Tool unclamp	
M30 Program end rewind	
M31 X-offset call	
M32 Turret CW / X+ offset call	
M33 Turret CCW / Z- offset call	
M34 Z+ offset call	
M35 Drilling tool offset call	
M38 Door close	
M39 Door open	

Simple Turning (Using turning cycle 952)

Part program	MPF/0RST			Description (file name)
Work piece	Cylinder	XA	26	Dia of work piece
		ZA	0	Start- point in z axis
		ZL	-70	total length of work piece
		ZB	-40	machining length
2	G71 G95;			Metric unit, feed mm/ revolution
4	G75 X0 Z0;			Going to home position
6	T1 D1;			Tool Change position no.1
8	MO3 S1500;			Spindle speed clockwise
10	G00 X26 Z3F.1;			Rapid tool movement
12	Contour call (Cycle 62)	ST		Sub program call by name
14	Stock Removal for turning (Cycle 952)	PRG	OD	Removal prog.name
		SC	2.00	Safety distance/clearance
		F	.1	Feed mm/revolution
		Machining	▼+▼▼▼	Roughing & Finishing
		FS	.01	Finishing feed
		Longitudinal	Outside	For turning outside
		D	0.1	Depth of cut
		UX	.020	Finishing allowance X-axis
		UZ	.020	Finishing allowance Z-axis
		DL	0	Dwell time
		BL	Cylinder	Select Blank(types of job)
		XD	26	Datum point X-axis-stock start
		ZD	2.0	Datum point Z-axis-stock start
		Relief cut	NO	Machine relief cut
Limit	NO	Limit machining area		
Accept				
16	G75 X0 Z0;			Going to home position
18	M05;			Spindle stop
20	M30			Program stop
22	E LAB A ST:			Code (sub prog.+Part prog)
24	G01 X15 Z0			Linear movement
26	G01X15 Z-25			Linear movement
28	G01 X20Z-25			Linear movement
30	G01X20Z-40			Linear movement
32	G01X26Z-40			Linear movement
34	M17			Sub program Exit

SIMPLE TURNING PROGRAM CYCLE - 952

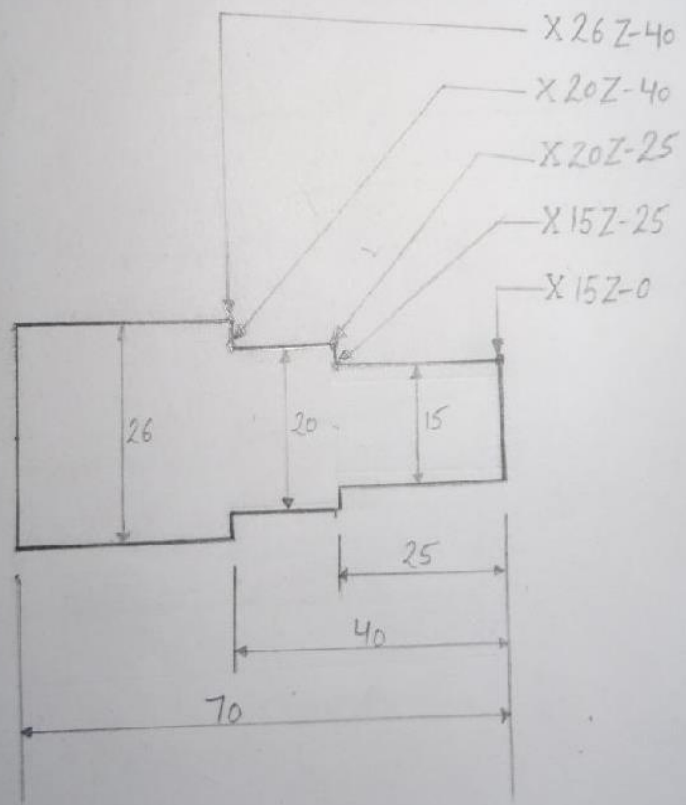

Tapper Turning (Using turning cycle 952)

Part program	MPF/0RTT		Description (file name)	
Work piece	Cylinder	XA	26	Dia of work piece
		ZA	0	Start- point in z axis
		ZL	-70	total length of work piece
		ZB	-40	machining length
2	G71 G95;		Metric unit , feed mm/ revolution	
4	G75 X0 Z0;		Going to home position	
6	T1 D1;		Tool Change position no.1	
8	MO3 S1500;		Spindle speed clockwise	
10	G00 X26 Z3F.1;		Rapid tool movement	
12	Contour call (Cycle 62)	TT	Sub program call by name	
14	Stock Removal for turning (Cycle 952)	PRG	OD	Removal prog.name
		SC	2.00	Safety distance/clearance
		F	.1	Feed/revolution
		Machining	▼+▼▼▼	Roughing & Finishing
		FS	.01	feed mm/ revolution
		Longitudinal	Outside	For turning outside
		D	0.1	Depth of cut
		UX	.020	Finishing allowance X-axis
		UZ	.020	Finishing allowance Z-axis
		DL	0	Dwell time
		BL	Cylinder	Select Blank type(job)
		XD	26	Datum point X-axis-stock start
		ZD	2.0	Datum point Z-axis-stock start
		Relief cut	NO	Machine relief cut
Limit	NO	Limit machining area		
	Accept			
16	G75 X0 Z0;		Going to home position	
18	M05;		Spindle stop	
20	M30		Program stop	
22	E LAB_A TT:		Code (sub prog.+Part prog)	
24	G01 X4 Z0		Linear movement	
26	G01X5 Z-1		Linear movement	
28	G01 X20 Z-35		Linear movement	
30	G01X24 Z-35		Linear movement	
32	G01X26 Z-40		Linear movement	
34	M17		Sub program Exit	

TAPPER TURNING PROGRAM CYCLE 952

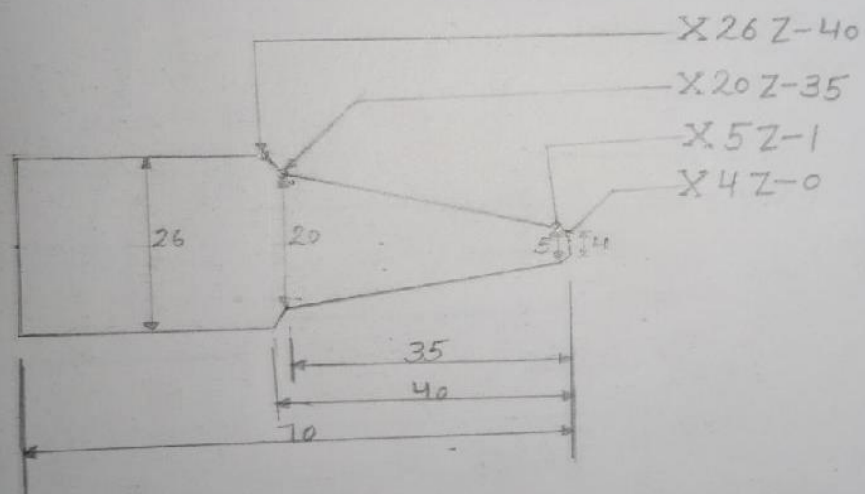

Radius Turning (Using turning cycle 952)

Part program	MPF/0RADIUS		Description (file name)	
Work piece	Cylinder	XA	26	Dia. of work piece
		ZA	0	start point in Z axis
		ZL	-70	total length work piece
		ZB	-40	machining length
2	G71 G95;		Metric unit , feed mm/ revolution	
4	G75 X0 Z0;		Going to home position	
6	T1 D1;		Tool Change position no.1	
8	MO3 S1500;		Spindle speed clockwise	
10	G00 X26 Z3F.1;		Rapid tool movement	
12	Contour call	RD	Sub program(Name) call	
14	Stock Removal for turning (Cycle 952)	PRG	OD	Removal prog.name
		SC	2.00	Safety distance/clearance
		F	.1	Feed mm/ revolution
		Machining	▼+▼▼▼	Roughing & Finishing
		FS	.01	Finishing feed
		Longitudinal	Outside	Machining direction position
		D	0.4	Depth of cut
		UX	.020	Finish allowance X-axis
		UZ	.020	Finishing allowance Z-axis
		DI	0	Continuous cut at θ
		BL	Cylinder	Select Blank type (job)
		XD	26	Datum point X-axis-stock start
		ZD	2.0	Datum point Z-axis-stock start
		Relief cut	NO	Machine relief cut
Limit	NO	Limit machining area		
Accept				
16	G75 X0 Z0;		Going to home position	
18	M05;		Spindle stop	
20	M30		Program stop	
22	E_LAB_A_RD:		Code (sub prog.+Part prog)	
24	G01 X6 Z0;		Linear movement	
26	G03 X16 Z-5 CR=5;		Circular Linear movement	
28	G01X16 Z-35;		Linear movement	
30	G02 X26 Z-40 CR=5		Circular Linear movement	
32	M17		Sub program Exit	

RADIUS TURNING PROGRAM CYCLE 952

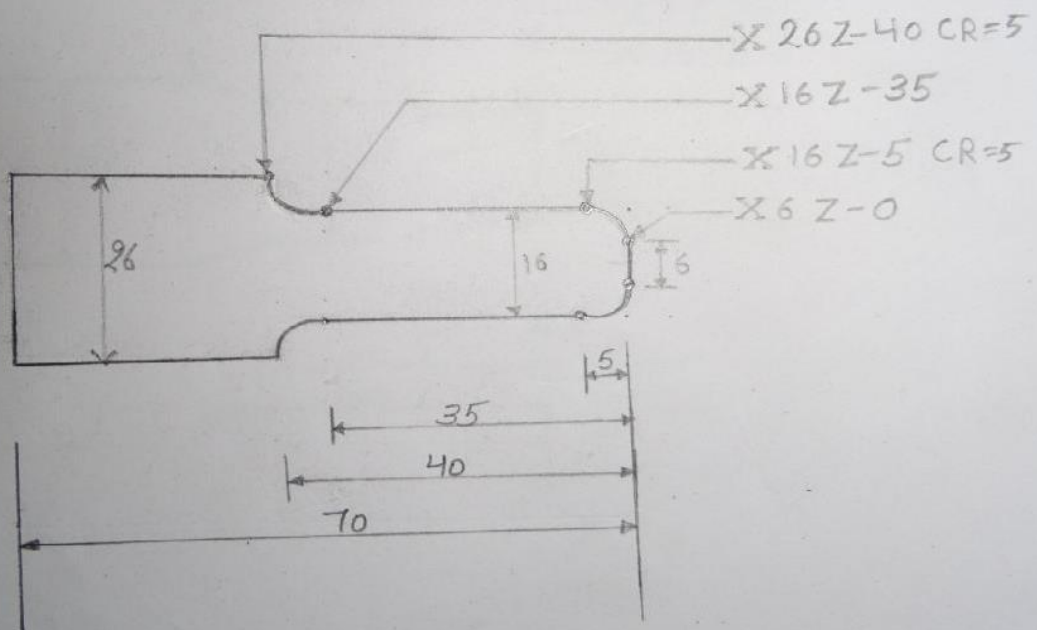

Multi Turning (Using turning cycle 952)

Part program	MPF/0RMT			Description(file name)
Work piece	Cylinder	XA	26	Dia of work piece
		ZA	0	Start- point in Z axis
		ZL	-70	total length of work piece
		ZB	-40	machining length
2	G71 G95;			Metric unit , feed / revolution
4	G75 X0 Z0;			Going to home position
6	T1 D1;			Tool Change position no.1
8	MO3 S1500;			Spindle speed clockwise
10	G00 X26 Z3F.1;			Rapid tool movement
12	Contour call (Cycle 62)	MT		Sub program(Name) call
14	Stock Removal for turning (Cycle 952)	PRG	OD	Removal prog.name
		SC	2.00	Safety distance/clearance
		F	.1	feed mm/ revolution
		Machining	▼+▼▼▼▼	Roughing & Finishing
		FS	.01	Finishing feed
		Longitudinal	Outside	For turning outside
		D	0.4	Depth of cut
		UX	.020	Finish allowance X-axis
		UZ	.020	Finishing allowance Z-axis
		DL	0	Dwell time
		BL	Cylinder	Select Blank type(job)
		XD	25	Datum point X-axis-stock start
		ZD	2.0	Datum point Z-axis-stock start
		Relief cut	NO	Machine relief cut
Limit	NO	Limit machining area		
	Accept			
16	G75 X0 Z0;			Going to home position
18	M05;			Spindle stop
20	M30			Program stop
22	E LAB A MT:			Code (sub prog.+Part prog)
24	G01 X16 Z0			Linear movement
26	G01 X17 Z-1			Linear movement
28	G01X17 Z-13			Linear movement
30	G03X21 Z-15 CR=2			Linear movement
32	G01 X25 Z-25			Linear movement
34	G01X26 Z-33			Linear movement
36	M17			Sub program Exit

MULTI TURNING PROGRAM

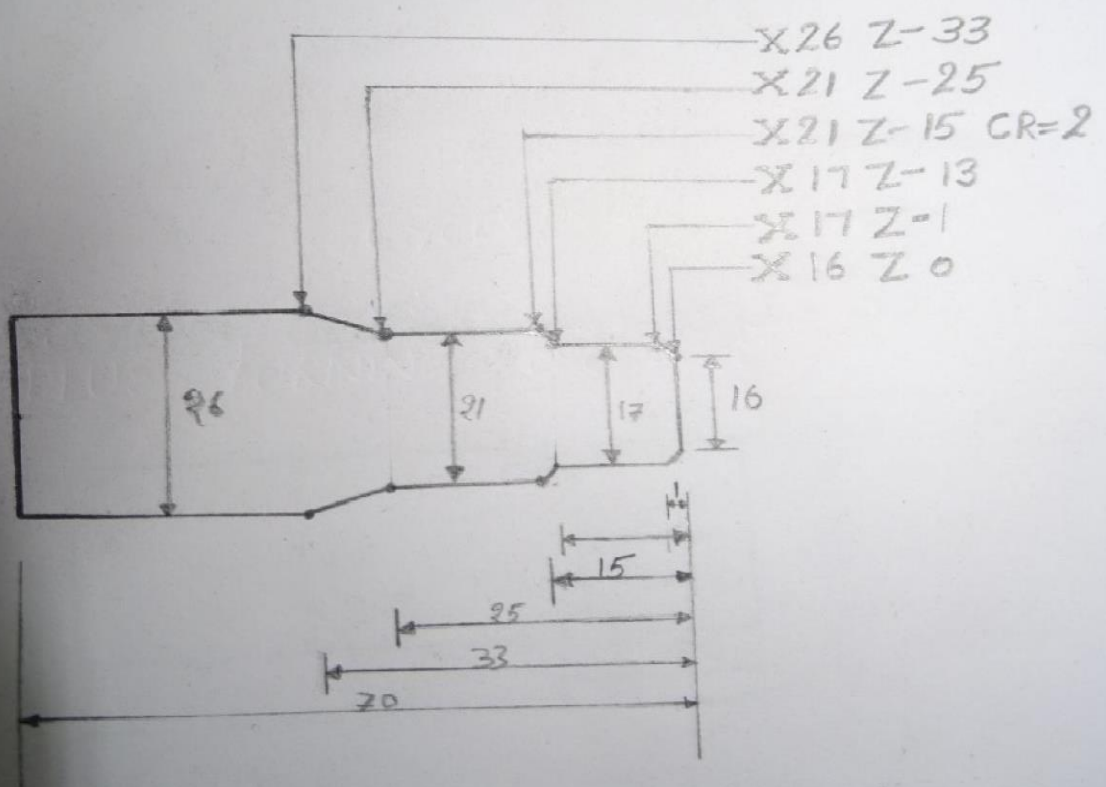

Threading External (Using threading cycle 99)

Part program	ORTHREADING			Description(file name)
Work piece--	Cylinder-	XA	26	Dia. of work piece
		ZA	0	Start- point in Z axis
		ZL	-70	total length work piece
		ZB	-40	machining length
2	G71 G95;			Metric unit , feed / revolution
3	G75 X0 Z0;			Going to home position
4	T5 D1;			Tool Change position no.1
5	MO3 S1000;			Spindle speed clockwise
6	G00 X26ZF.1;			Rapid tool movement
	Threading (Cycle99)	Table	ISO	Metric
		select	M 10	Select table value
		P	1.5	pitch
		Machining	▼+▼▼▼	Roughing & Finishing
		Linear		
		External		
		X	26	Reference point X for thread
		Z	0	Reference point Z for thread
		ZI	-15	length of thread
		LW	2	Thread advance distance
		LR	0	Thread run out distance
		HI	0.919	Height of thread
		α P	30°	Slope angle of thread
		DI	0.1	In feed depth of cut
		U	0.01	Finishing allowance
		NN	4	No. of idle pass after thread
		VR	1	Return safety distance
		Multiple	No	Starting No. of thread
		α θ	0.000	Starting angle of thread
			Accept	
7	G75 X0 Z0;			Going to home position
8	M05;			Spindle stop
9	M30			

THREADING CYCLE 99

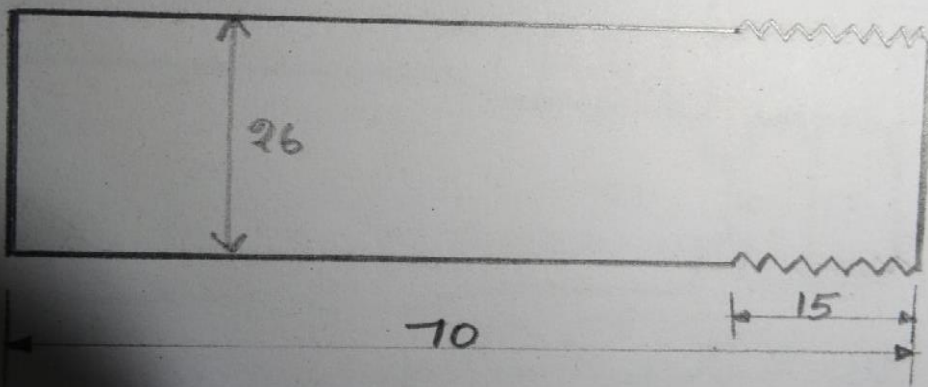

Grooving (Using grooving cycle 930)

Part program	GROOVING		Description(file name)	
Work piece	Cylinder	XA	26	Dia of work piece
		ZA	0	Start- point in Z axis
		ZL	-70	total length work piece
		ZB	-40	machining length
2	G71 G95;		Metric unit , feed / revolution	
3	G75 X0 Z0;		Going to home position	
4	T7 D1;		Tool Change position no.1	
5	MO3 S1000;		Spindle speed clockwise	
6	G00 X26 Z-20F.1;		Rapid tool movement	
8	Grooving (Cycle 930)	SC	2.00	Safety distance/clearance
		F	.1	feed mm/ revolution
		Machining	▼+▼▼▼	Roughing & Finishing
		Pos.		1. Position of machining 2. Reference point
		X0	26	Reference point X
		Z0	-15	Reference point Z
		B1	5	Groove width
		T1	20	Un machined up to groove
		D	.5	Depth of each cut
		UX	0.1	Finishing allowance of X axis
		UZ	0.1	Finishing allowance of Z axis
		N	01	No. of groove
		Accept		
9	G75 X0 Z0;		Going to home position	
10	M05;		Spindle stop	
11	M30		Program stop	

GROOVING OPERATION CYCLE - 930

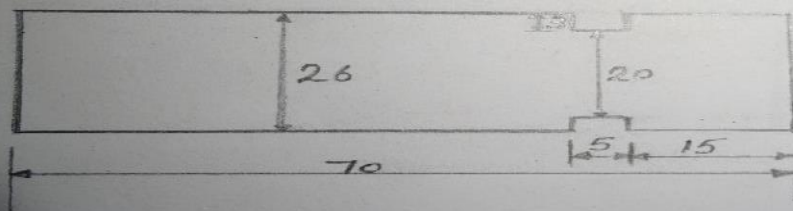

Multi function turning

Part program	MPF/0RMF		Description(file name)	
Work piece	Cylinder	XA	26	Dia of work piece
		ZA	0	Start- point in Z axis
		ZL	-70	total length of work piece
		ZB	-40	machining length
2	G71 G95;		Metric unit , feed / revolution	
4	G75 X0 Z0;		Going to home position	
6	T1 D1;		Tool Change position no.1	
8	MO3 S2000;		Spindle speed clockwise	
10	G00 X26 Z3 F.1;		Rapid tool movement	
12	Contour call (Cycle 62)	MFT	Sub program(Name) call	
14	Stock Removal for turning(Cycle 952)	PRG	OD	Removal prog.name
		SC	2.00	Safety distance/clearance
		F	.1	feed mm/ revolution
		Machining	▼+▼▼▼	Roughing & Finishing
		FS	.01	Finishing feed
		Longitudinal	Outside	For turning outside
		D	0.1	Depth of cut
		UX	.020	Finish allowance X-axis
		UZ	.020	Finishing allowance Z-axis
		DL	0	Dwell time
		BL	Cylinder	Select Blank type(job)
		XD	26	Datum point X-axis-stock start
		ZD	2.0	Datum point Z-axis-stock start
		Relief cut	NO	Machine relief cut
Limit	NO	Limit machining area		
	Accept			
16	G75 X0 Z0;		Going to home position	
18	M05;		Spindle stop	
20	T7D1		Tool Change position no.2	
22	M03 S600		Spindle speed clockwise	
24	G00X17.5 Z-13F.1;		Rapid tool movement	
28	Grooving cycle (Cycle 930)	SC	2.00	Safety distance/clearance
		F	.01	feed mm/ revolution
		Machining	▼+▼▼▼	Roughing & Finishing
		Pos.		Position of machining Reference point
		X0	17	Reference point X
		Z0	-10	Reference point Z
		B1	3	Groove width
		T1	10	Un machined up to groove
		D	.5	Depth of each cut
		UX	0.1	Finishing allowance of X-axis
		UZ	0.1	Finishing allowance of Z-axis
N	01	No. of groove		
	Accept			
30	G75 X0 Y0		Going to home position	

32	M05	Spindle stop		
34	T5D1	Tool Change position no.3		
36	M04 S600	Spindle speed clockwise		
38	G00 X17 Z5	Rapid tool movement		
40	External Threading cycle (Cycle952)	Table	ISO	
		select	M 10	Select table value
		P	1.5	pitch
		Machining	▼+▼▼ ▼	Roughing & Finishing
		Linear		
		External-thread		
		X	17	Reference point X for thread
		Z	0	Reference point Z for thread
		ZI	-10	length of thread
		LW	2	Thread advance distance
		LR	0	Thread run out distance
		HI	0.920	Height of thread
		αP	30°	Slope angle of thread
		DI	0.1	In feed depth
		U	0.01	Finishing allowance
		NN	2	No. of idle pass after thread
		UR	1	Return safety distance allowance
	Multi-pal	No	Starting No. of thread	
	αθ	0.000	Starting angle of thread	
	Accept			
42	G75X0Y0	Going to home position		
44	M05	Spindle stop		
46	M30	Program stop		
22	E LAB A MFT:	Code (sub prog.+Part prog)		
24	G01 X16 Z0	Linear movement		
26	G0X17 Z-1	Linear movement		
28	G01X17 Z-13	Linear movement		
30	G03X21 Z-15 CR=2	Linear movement		
32	G01 X25 Z-25	Linear movement		
34	G01X26 Z-33	Linear movement		
36	M17	Sub program Exit		

MULTI FUNCTION, GROOVING & THREADING

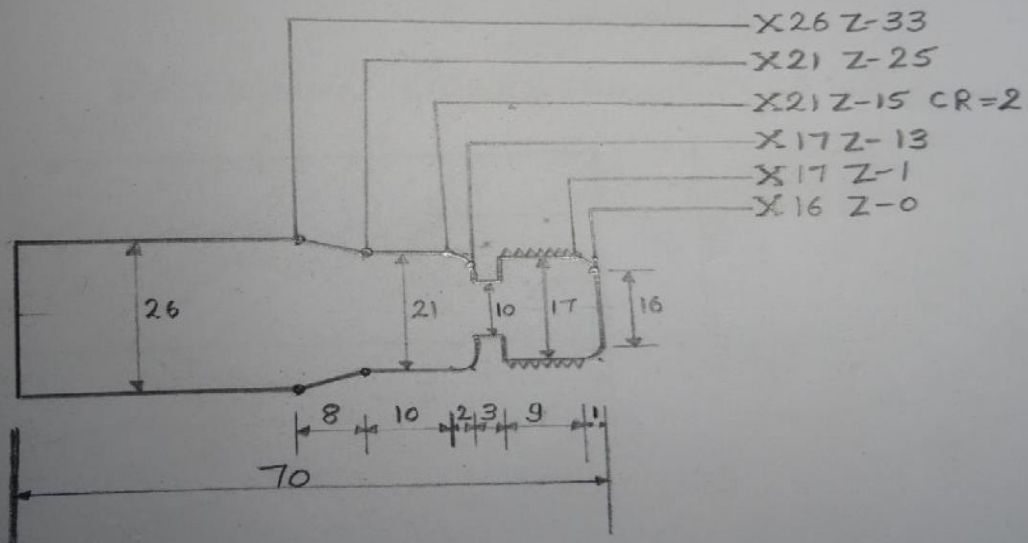

Drilling (Using drilling cycle 83)

Part program	MPF/ OR DRILLING			Function
Work piece--	Cylinder	XA	32	Dia. of work piece
		ZA	0	Start- point in Z axis
		ZL	-70	total length work piece
		ZB	-50	machining length
2	G71 G95;			Metric Unit , feed / revolution
3	G75 X0 Z0;			Going to home position
4	T4 D1;			Tool Change position no.1
5	MO3 S1000;			Spindle speed clockwise
6	G00 X0 Z5F.1;			Rapid tool movement
9	Centering drill (Cycle 81)	PL	G17 XY	Machining plane
		RP	5.00	Retraction plane
		SC	2.00	Safety distance
		Z0	0.0	Reference point Z
		1. Shank 2. Tip	Select	Drilling depth up to shank Drilling depth up to tip
		Z1	-2	Length of drilling depth
		DT	0.00	Dwell time at final depth
		Accept		
10	G75 X0 Z0;			Going to home position
11	M05;			Spindle stop
12				Going to home position
6	T6 D1;			Tool Change position no.1
8	MO3 S800;			Spindle speed clockwise
10	G00 X0 Z5F.5;			Rapid tool movement
12.	Drilling cycle (Cycle 83)	PL	G17 XY	Machining plane
		RP	5.00	Retraction plane
		SC	2.00	Safety distance/clearance
		Chip removal		
		Z0	0	Reference point Z
		Shank	select	Drilling depth up to shank
		Z1	-24	Length of drilling depth
		D	-1.00	1st drilling depth stroke
		D1	50.00%	Feed percentage for 1st in feed
		DF	100%	Percentage for every further in feed
		Lead distance		Automatically / Manually
		DTB	0.00 s	Dwell time at drilling depth in second
		DT	0.00 s	Dwell time at final depth in second
DTS	0.00 s	Dwell time for removing chips in second		
14	G75 X0 Z0;			Going to home position
16	M05			Program stop
18	M30			

DRILLING OPERATION CYCLE 83

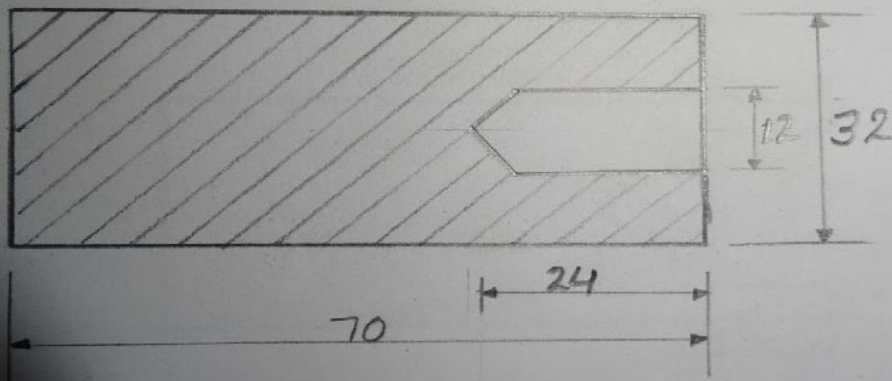

Drilling Boring

Part program	MPF/0RDB			Function
Work piece--	Cylinder	XA	32	Dia. of work piece
		ZA	0	Start- point in Z axis
		ZL	-70	total length work piece
		ZB	-40	machining length
2	G71 G95;			Metric Unit, feed / revolution
3	G75 X0 Z0;			Going to home position
4	T4 D1;			Tool Change position no.1
5	MO3 S1000;			Spindle speed clockwise
6	G00 X0 Z5F.1;			Rapid tool movement
9	Centering drill (Cycle 81)	PL	G17 XY	Machining plane
		RP	5.00	Retraction plane
		SC	2.00	Safety distance/clearance
		Z0	0.0	Reference point Z
		1. Shank 2. Tip	Select	Drilling depth related to shaft Drilling depth related to Tip
		Z1	-2	Final drilling depth
		DT	0.00	Dwell time at final depth
		Accept		
10	G75 X0 Z0;			Going to home position
11	M05;			Spindle stop
12	G75 X0 Z0;			Going to home position
6	T6 D1;			Tool Change position no.1
8	MO3 S800;			Spindle speed clockwise
10	G00 X0 Z5F.5;			Rapid tool movement
12.	Drilling cycle (Cycle 83)	PL	G17 XY	Machining plane
		RP	5.00	Retraction plane
		SC	2.00	Safety distance/clearance
		Chip removal		
		Z0	0	Reference point Z
		Shank	select	Drilling depth up to shank
		Z1	-24	Length of drilling depth
		D	-1.00	1st drilling depth stroke
		D1	50.00%	Feed percentage for 1st in feed
		DF	100%	Percentage for every further in feed
		Lead distance		Automatically / Manually
		DTB	0.00 s	Dwell time at drilling depth in second
		DT	0.00 s	Dwell time at final depth in second
		DTS	0.00 s	Dwell time for removing chips in second
14	G75 X0 Z0;			Going to home position
16	M05			Program stop
18	M30			

20	T2 D1;			Tool Change position no.1
22	MO3 S1500;			Spindle speed clockwise
24	G00 X0 Z5;			Rapid tool movement
26	Contour call (Cycle62)	BOR		Code name(sub prog.+prog)
28	Stock Removal for boring (Cycle 952)	PRG	ID	Removal prog.name
		SC	2.00	Safety distance/clearance
		F	.1	feed mm/ revolution
		Machining	▼+▼▼ ▼	Roughing & Finishing
		FS	.01	Finishing feed
		Longitudinal	Inside	
		RP	0.5	Retraction plane
		D	0.1	Depth of cut
		UX	0.02	Finishing allowance in X-axis
		UZ	0.02	Finishing allowance in Z-axis
		DI	0.00	Continuous cut
		BL	cylinder	Select blank (job)
		XD	12	Datum point X-axis-stock start
		ZD	2.000	Datum point Z-axis-stock start
	Relief cut	NO	Machine relief cut	
	Limit	NO	Limit machining area	
30	G75 X0 Z0;			Going to home position
32	M05;			Spindle stop
46	M30			Contour(sub program) Name
48	E LAB A BOR:			Code (sub prog.+Part prog)
50	G00 X26 Z0;			Rapid movement
52	G02 X22Z-2 CR=2			Linear movement
54	G01X22Z-12			Linear movement
56	G01 X16Z-18;			Linear movement
58	G01 X12Z-18			Linear movement
60	M17			Sub program Exit

BORING OPERATION

BORING - 01

