

# CNC Milling Basics



Richland College

DALLAS COUNTY COMMUNITY COLLEGE DISTRICT

# Introduction

- CNC milling machines perform same functions as manual, and creates arcs, contours and 3D surfaces



CNC milling machines can produce complex part surfaces that would be virtually impossible to produce with manual milling machines.



# Types of CNC Milling Machines

- Two classes of machining centers:
  - Vertical spindle and horizontal spindle
- Types of milling machines: vertical and horizontal machining centers (VMC and HMC)
- ATC types: carousel-type and swing-arm-type



A vertical CNC milling machine



A vertical machining center



Courtesy of Bridgeport Milling

Photo courtesy of Haas Automation, Inc.



Richland College

DALLAS COUNTY COMMUNITY COLLEGE DISTRICT

A vertical machining center (VMC). Notice the similarities to a manual vertical milling machine.

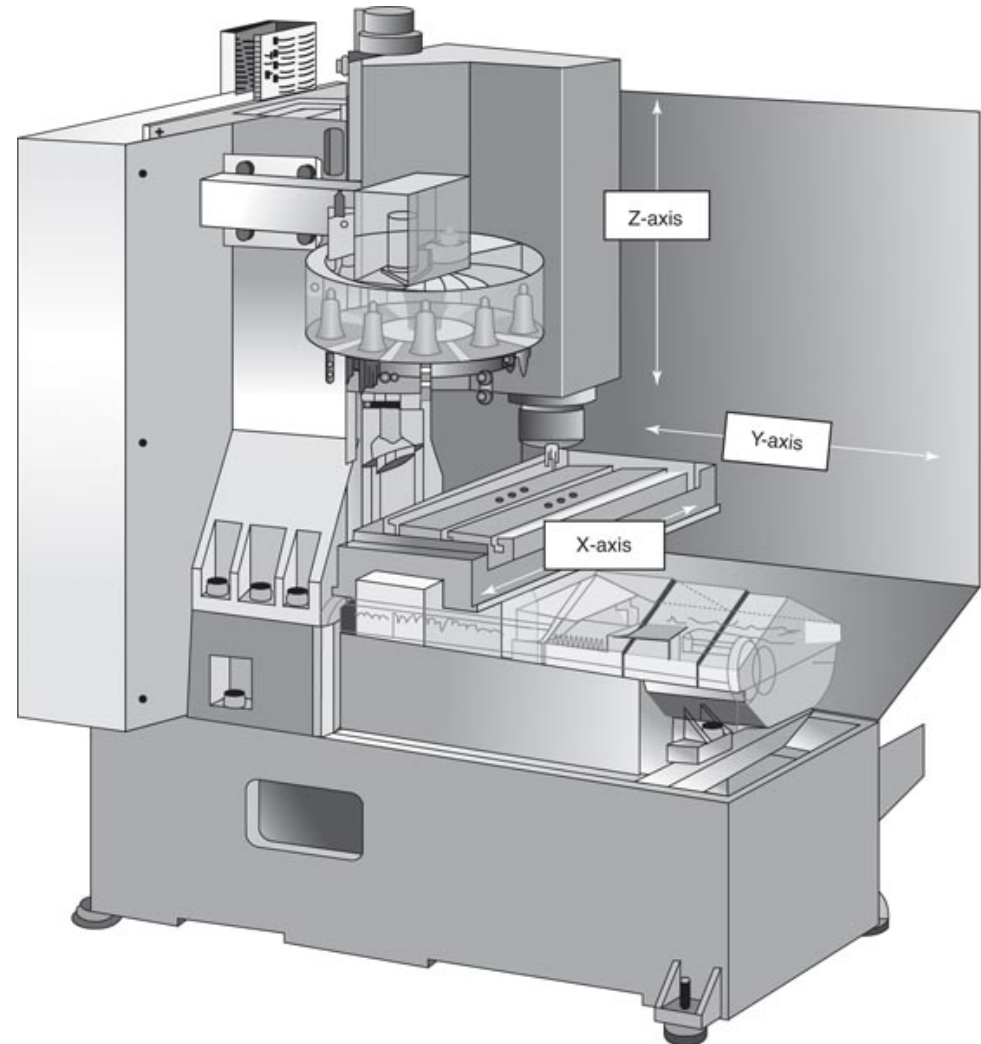

Copyright © 2015 Cengage Learning®



Richland College

DALLAS COUNTY COMMUNITY COLLEGE DISTRICT

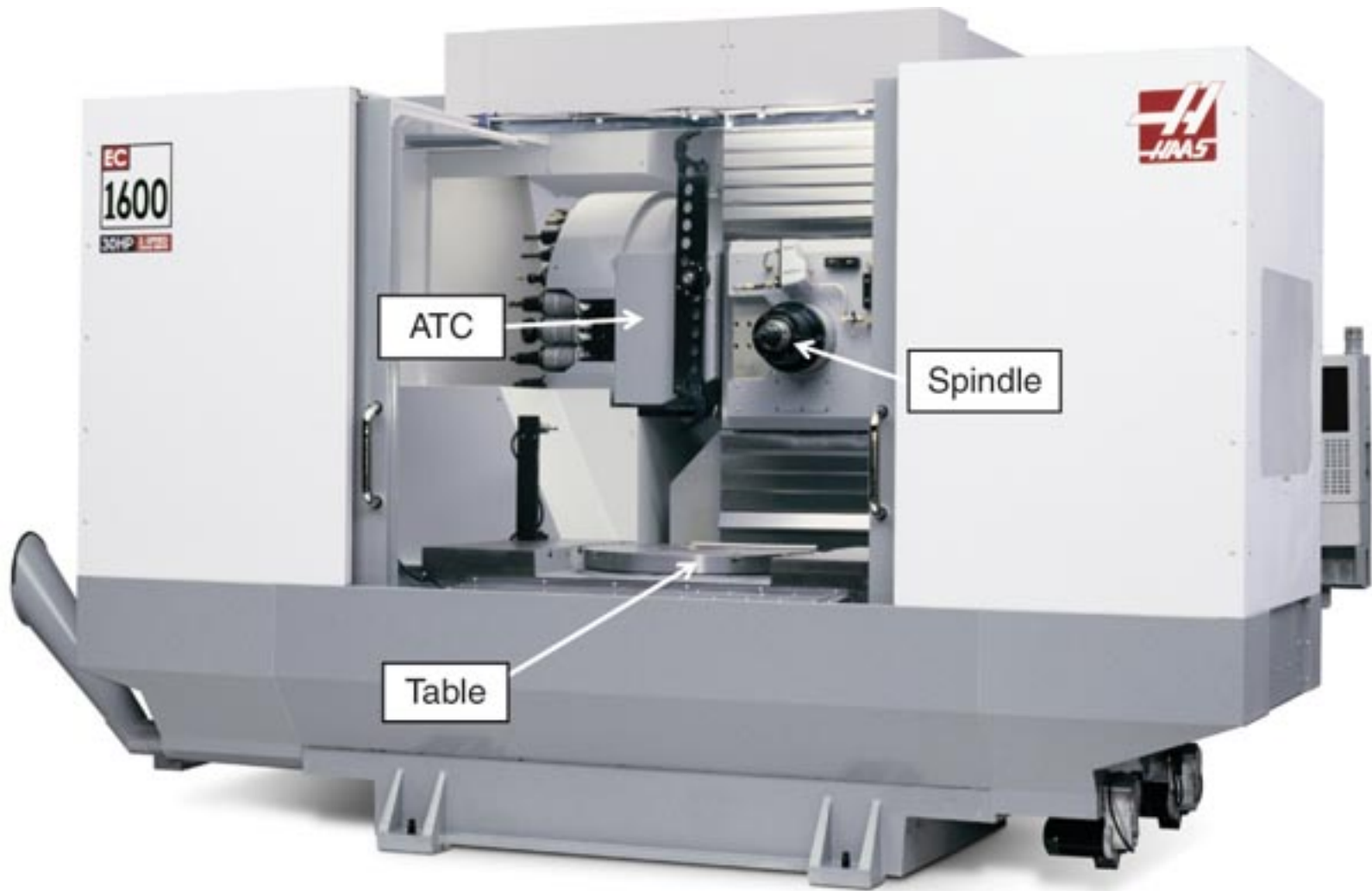

Photo courtesy of Haas Automation, Inc

A horizontal machining center (HMC). Notice the orientation of the spindle, table, and ATC.



Richland College

DALLAS COUNTY COMMUNITY COLLEGE DISTRICT



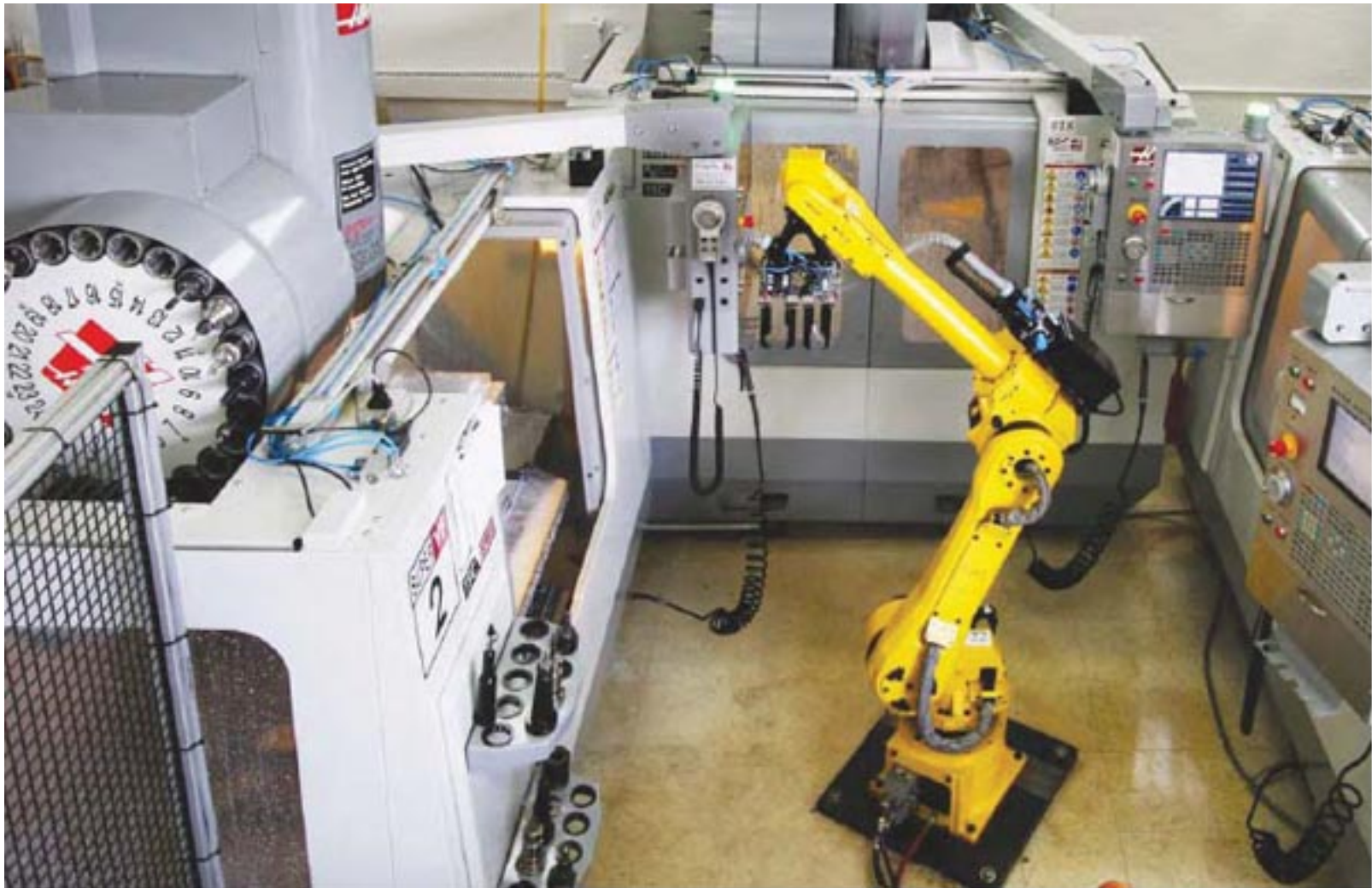

Photo courtesy of Haas Automation, Inc.

A manufacturing cell with multiple CNC machining centers and automated part handling.



Richland College

DALLAS COUNTY COMMUNITY COLLEGE DISTRICT

<https://proleantech.com/> 7



Courtesy of Mig Americas

A carousel-type ATC.



Richland College

DALLAS COUNTY COMMUNITY COLLEGE DISTRICT





Courtesy of Mag Americas

The swing-arm-type ATC changes tools much faster than the carousel-type ATC.



Richland College

DALLAS COUNTY COMMUNITY COLLEGE DISTRICT

# Toolholding

- Toolholding
  - CNC spindle types and tool attachment styles
  - Workholding: many devices available



National Machine Tool Builder (NMTB) toolholders in 30, 35, 40, 45, and 50 size tapers.

Copyright © 2015 Cengage Learning™



Retention knobs thread into tapered toolholders to secure the holder in the machine spindle.



Courtesy of Lyndex-Nikkon, Inc.



Richland College

DALLAS COUNTY COMMUNITY COLLEGE DISTRICT

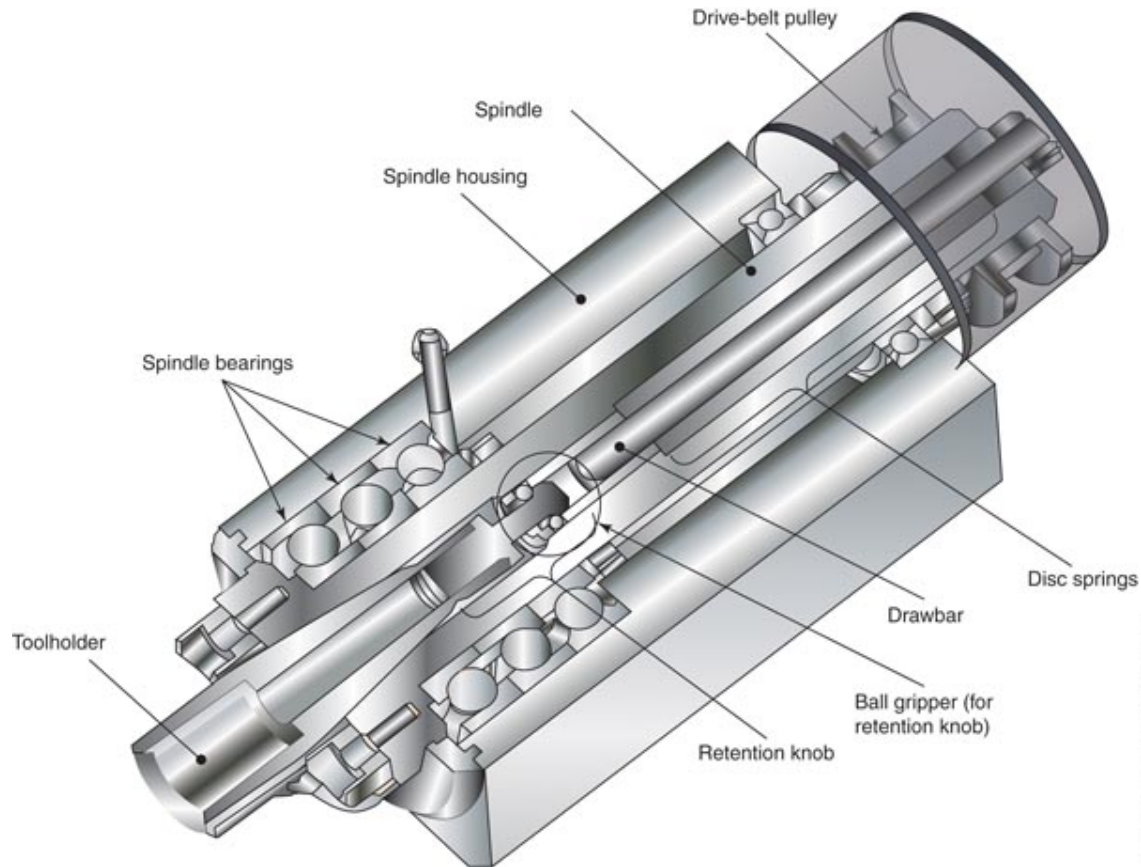

A cutaway view showing the many parts of a milling spindle. Notice how the ball gripper mechanism at the end of the drawbar grasps the retention knob. Spring tension from a series of disc springs pulls on the drawbar to secure the toolholder taper.

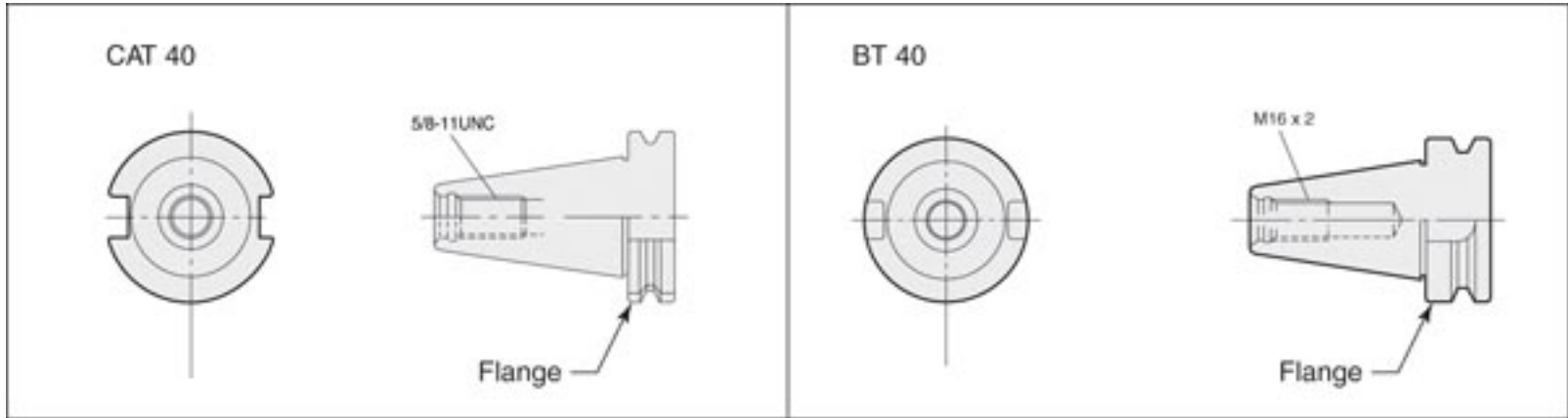

Copyright © 2015 Cengage Learning®

A CAT holder and a BT holder. Notice the difference in the size of the flanges and the location of the grooves.



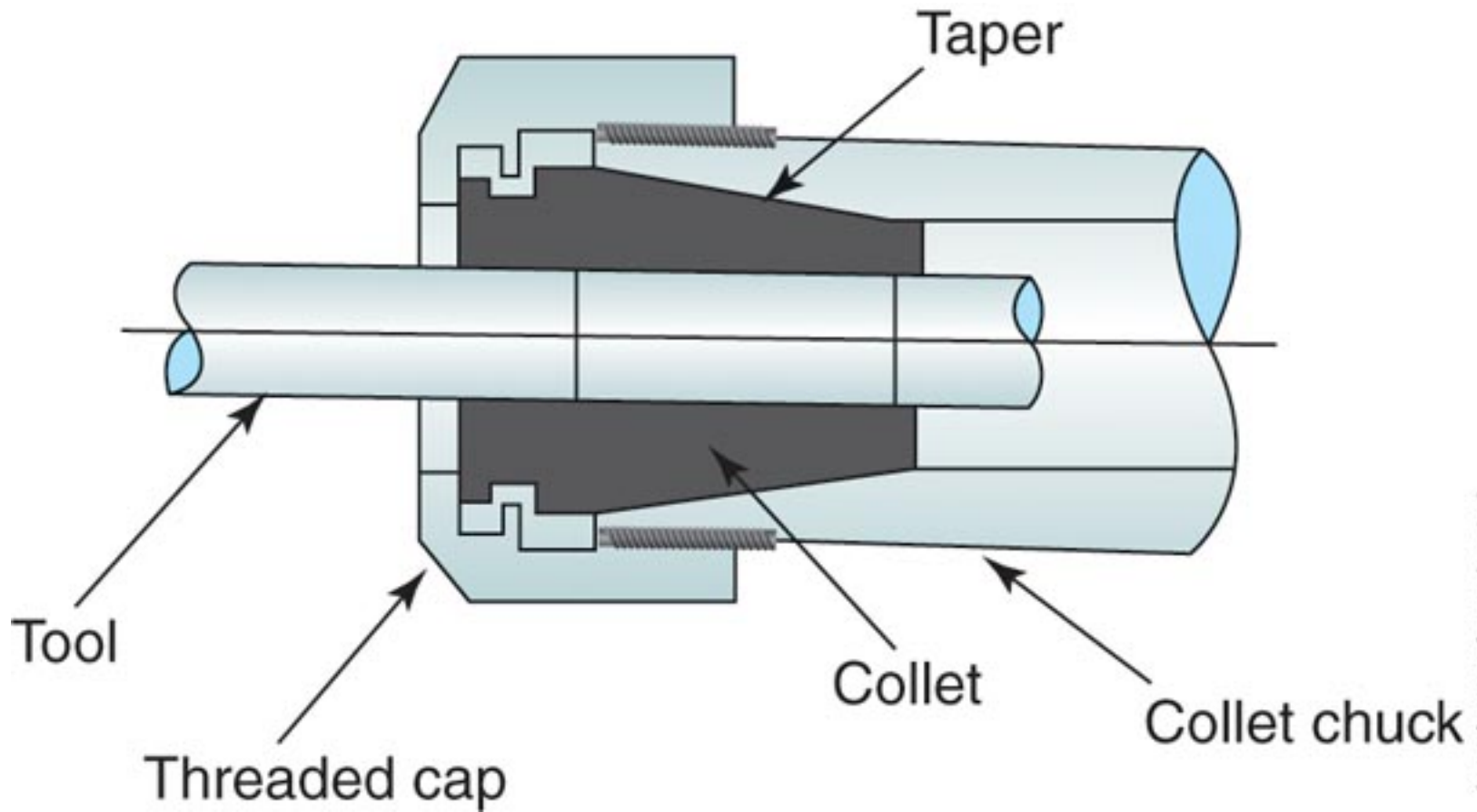

A collet chuck grips a tool shank by tightening the threaded cap.





Courtesy of Lyndee Mikken, Inc



Courtesy of Lyndee Mikken, Inc

(A) ER-, (B) TG-, and (C) DA-style collets.



Courtesy of Lyndee Mikken, Inc



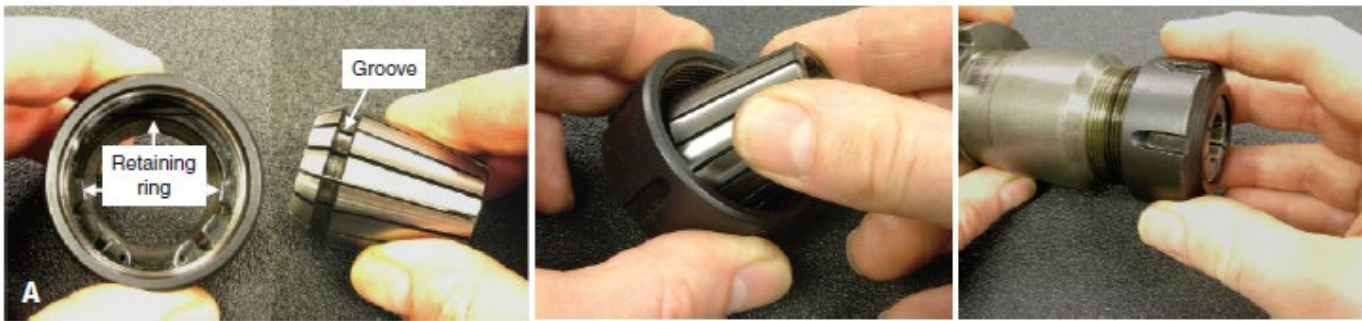

(A) The groove on an ER collet snaps into a retaining ring in the threaded cap and the cap is then threaded into the collet chuck. (B) DA collets slip into the chuck and then the cap is threaded onto the chuck. (C) The toolholder is then mounted in a bench-top clamping device, the tool is inserted in the collet, and the cap is tightened.

All images Copyright © 2015 Cengage Learning®.





Photo courtesy of Haas Automation, Inc.

- (A) A shrink-fit toolholder.
- (B) The machine that assembles and disassembles shrink-fit tooling.



courtesy of Bilz Tool Co



(A) A key-type chuck with a quick change size 30 NMTB taper and (B) a keyless chuck with a CAT type flange..



Copyright © 2015 Cengage Learning™



Courtesy of Lyndee Mikken, Inc.



Richland College

DALLAS COUNTY COMMUNITY COLLEGE DISTRICT



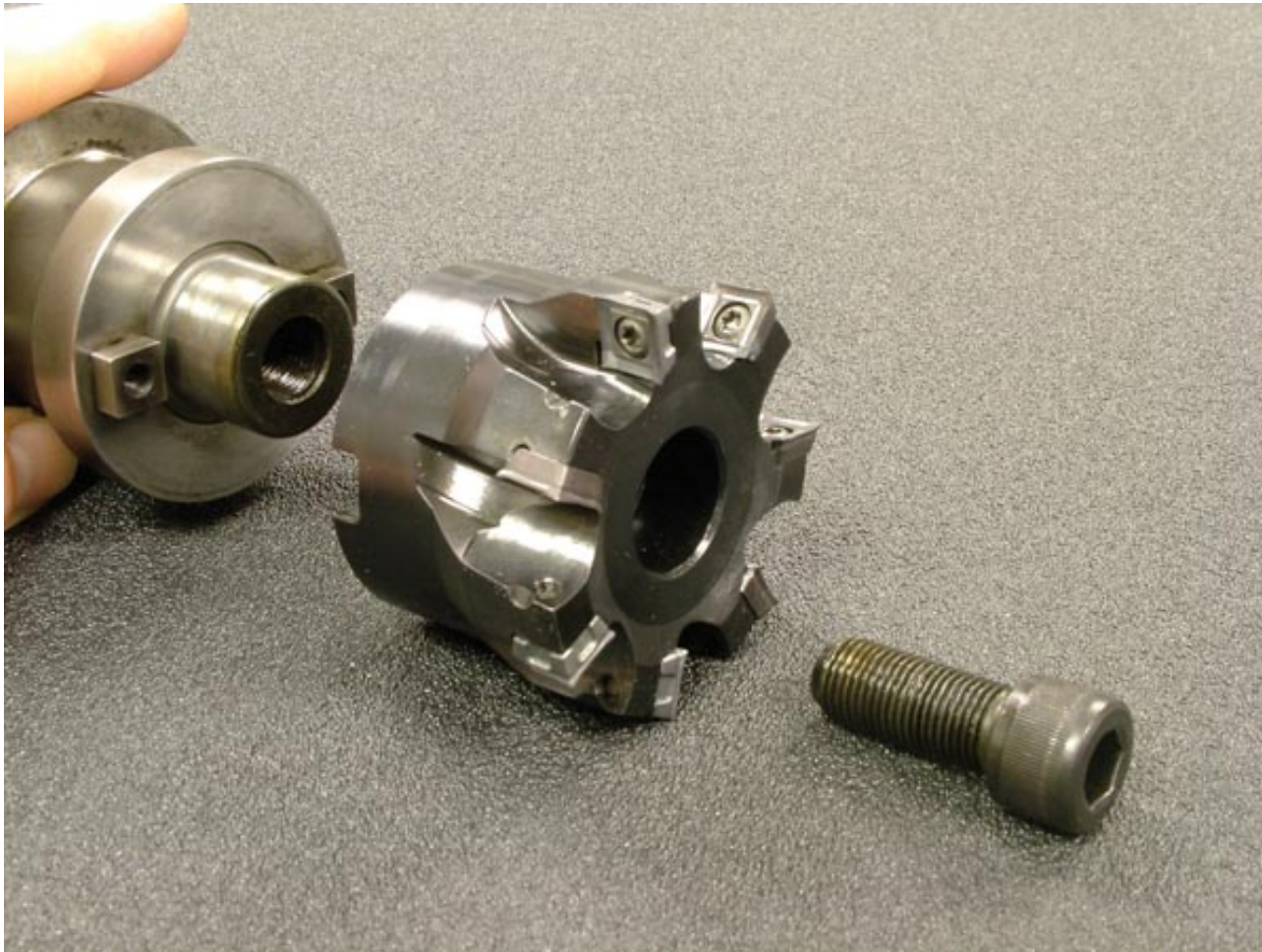

Copyright © 2015 Cengage Learning®

A face mill and toolholder.



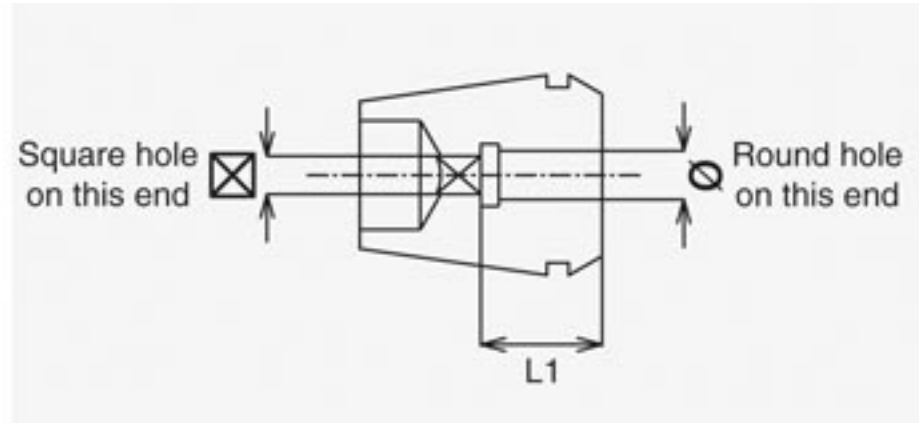

An ER collet with an internal square for holding taps rigidly.



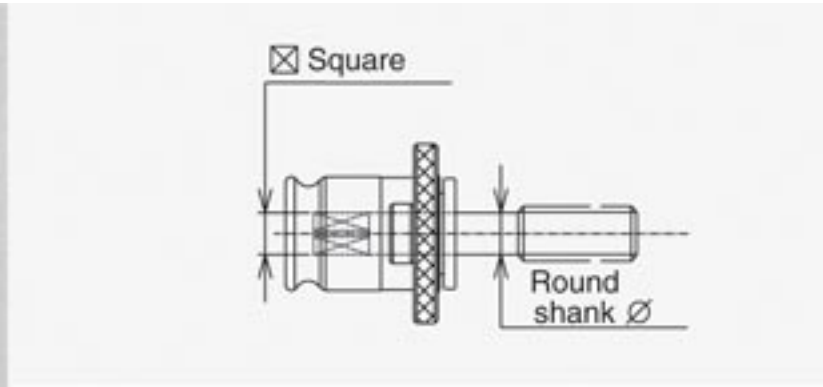

Courtesy of Lyndex-Mikken, Inc



Courtesy of Lyndex-Mikken, Inc

(A) A quick-change tap adapter designed to quickly mount taps into a  
(B) floating holder.

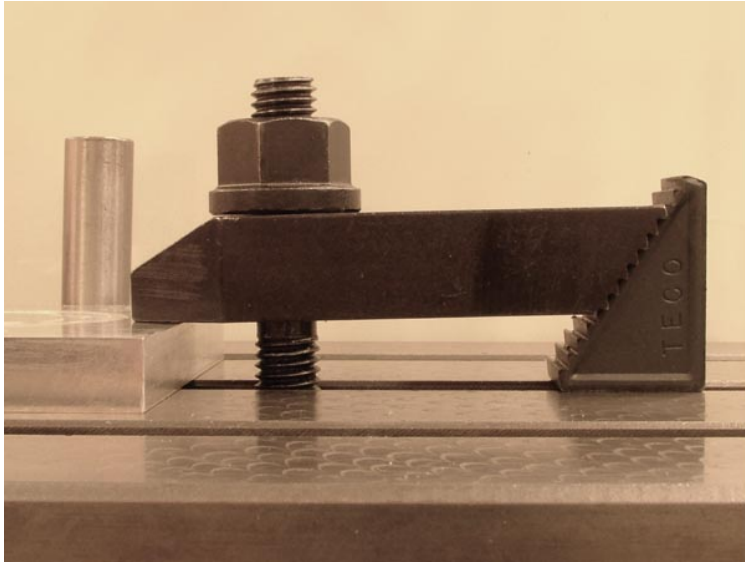

Step clamps

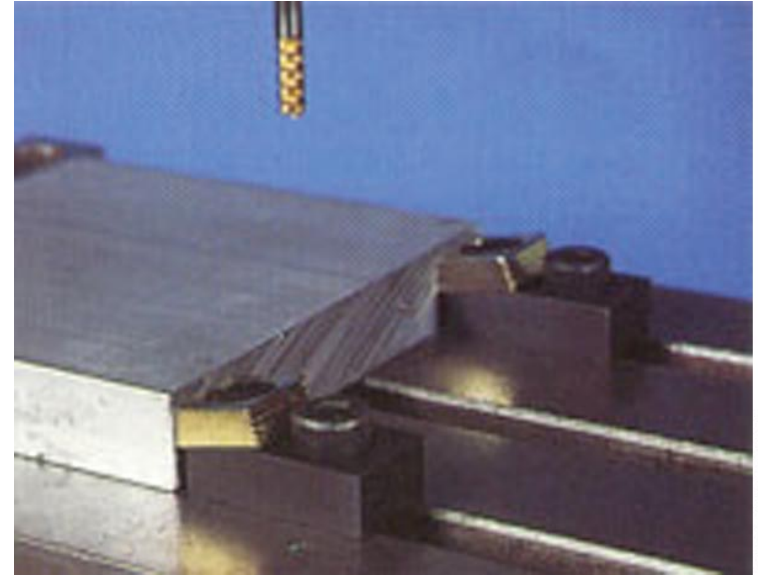

Toe clamps

Toggle clamps

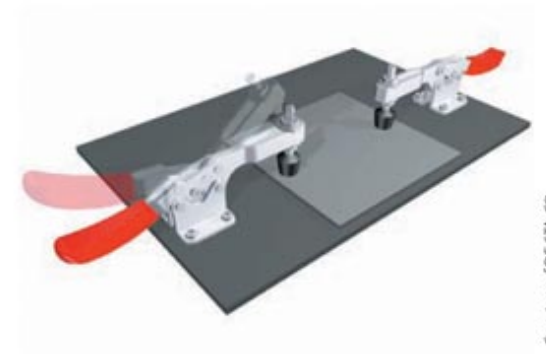
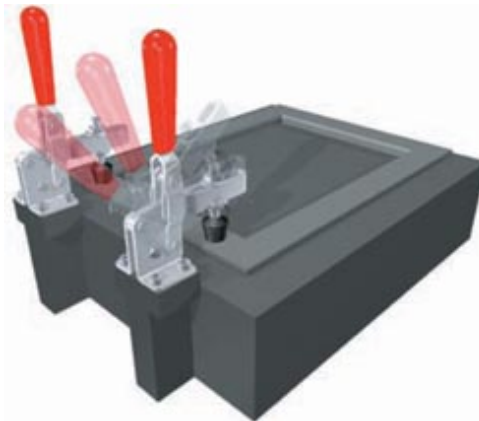



Copyright © 2015 Cengage Learning®

A large workpiece clamped to the table of a VMC using step clamps.



Richland College

DALLAS COUNTY COMMUNITY COLLEGE DISTRICT



Courtesy of Kurt MFG

A vise with two moveable jaws can hold two parts in one setup.



Richland College

DALLAS COUNTY COMMUNITY COLLEGE DISTRICT

This multi-sided vertical double vise has machinable aluminum jaws, or soft jaws, that can be machined to match the shape of the workpiece. Soft jaws can also be made of soft steel or cast iron.

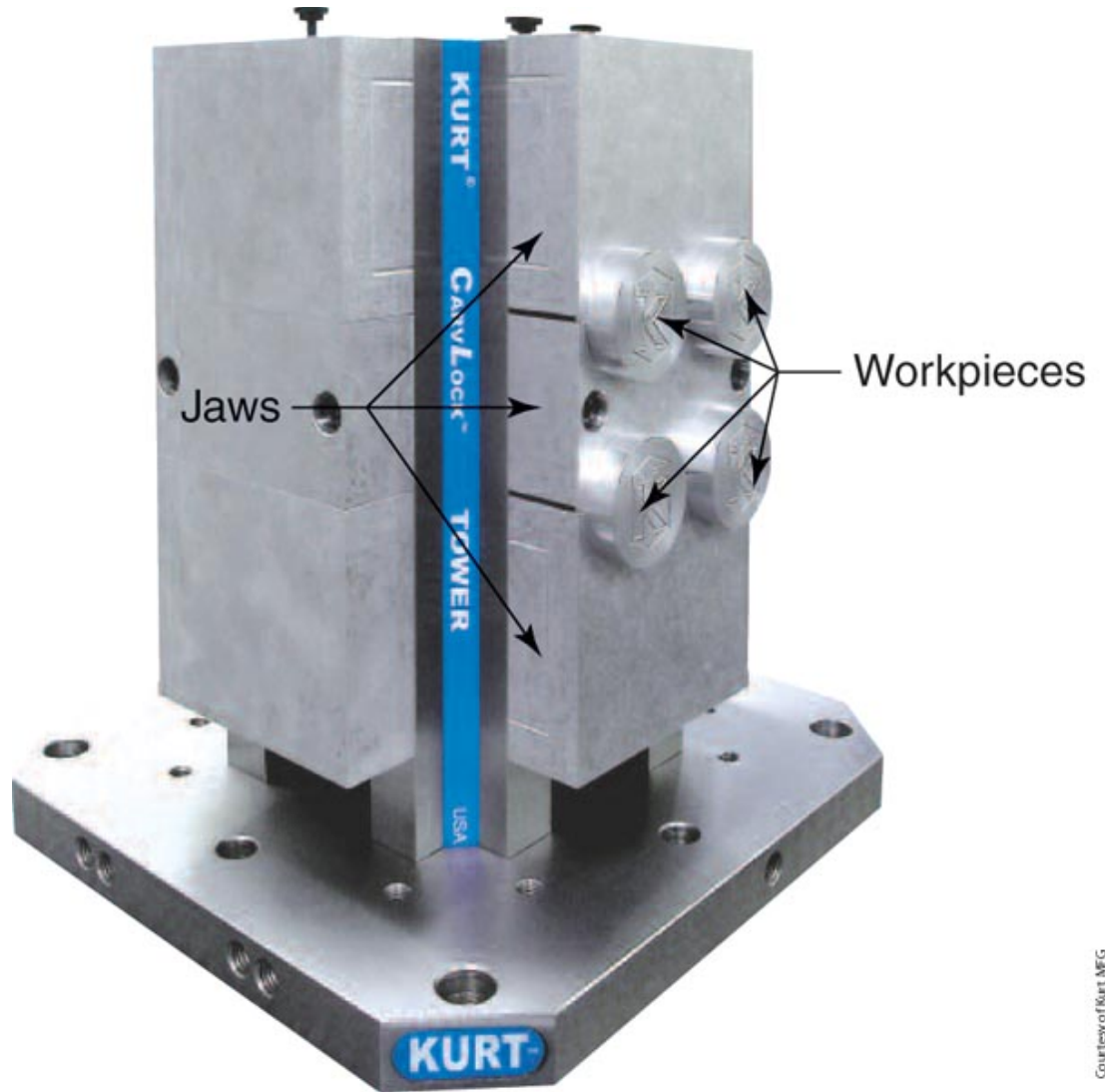

Courtesy of Kurt MFG



Richland College

DALLAS COUNTY COMMUNITY COLLEGE DISTRICT



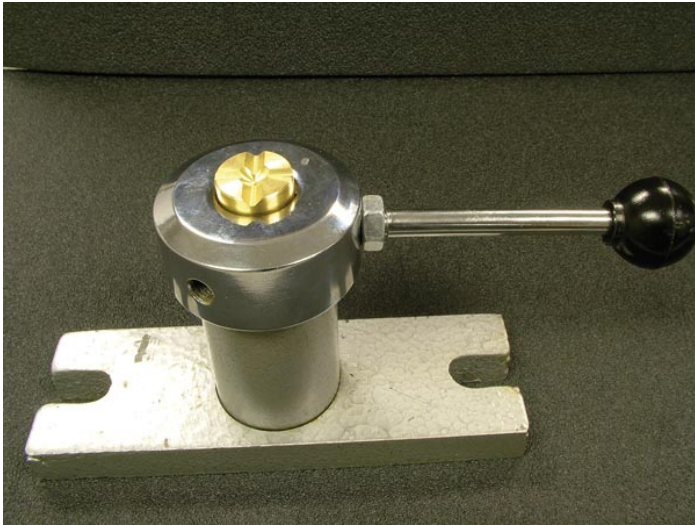

Copyright © 2011 Cengage Learning™

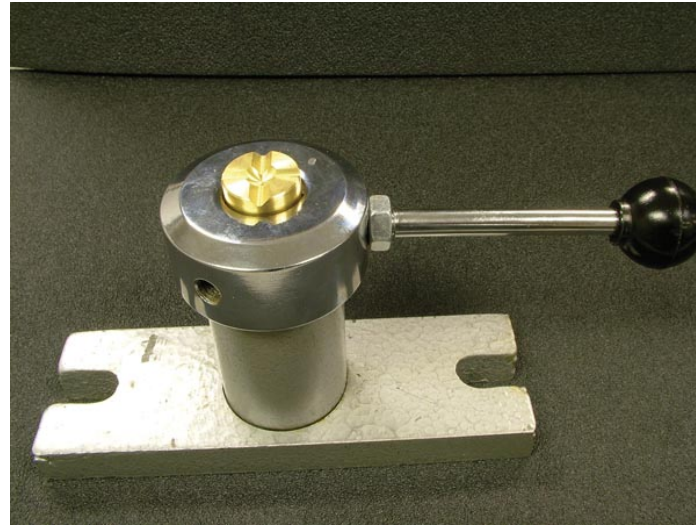

Copyright © 2011 Cengage Learning™

Manual collet fixtures

A programmable CNC rotary axis



Photo courtesy of Hars Automation, Inc.





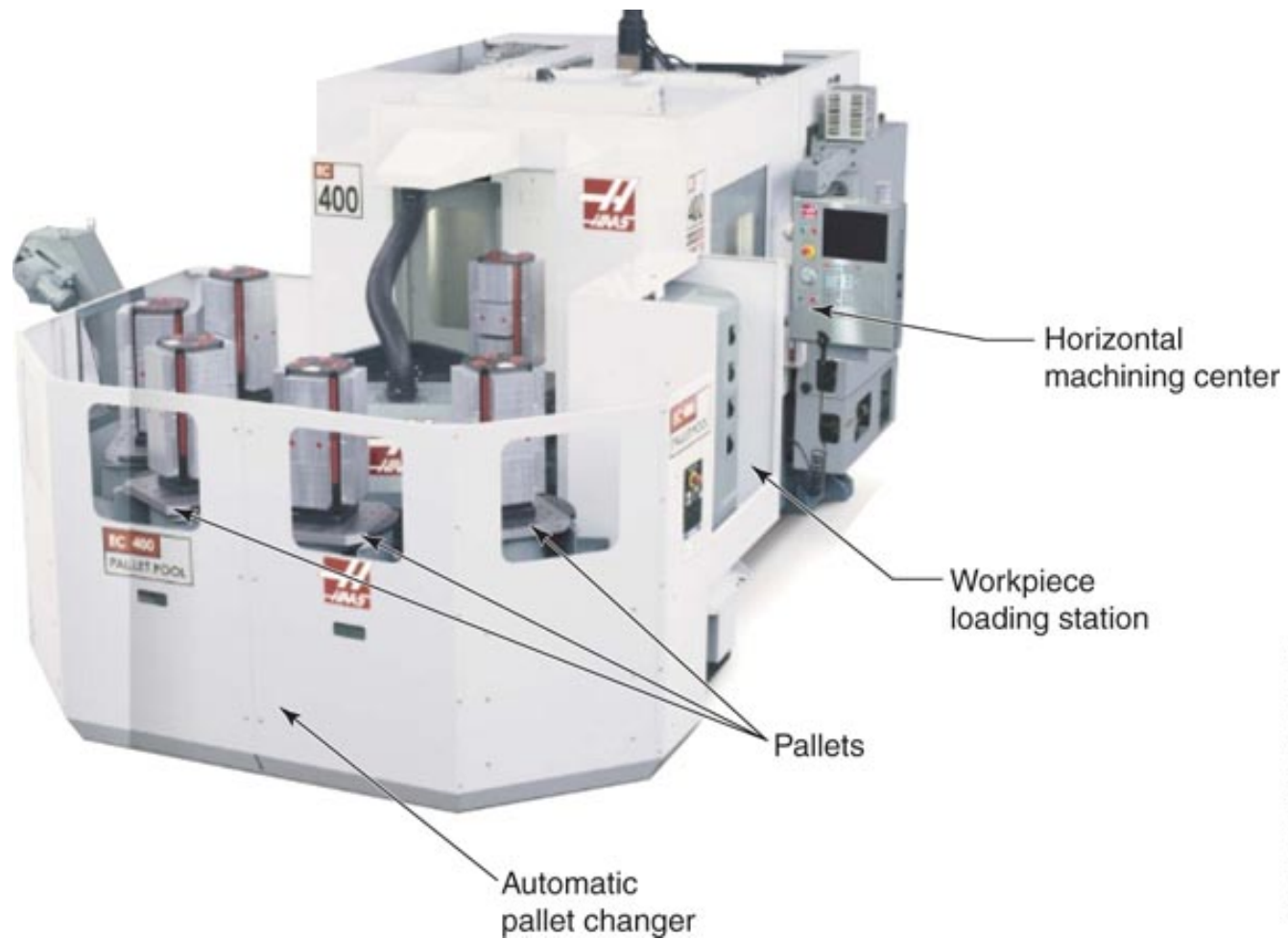

This machining center has an APC that uses six pallets. The machine can be programmed to load any of the pallets automatically. Work is loaded on each pallet at the station on the right side of the APC.





Courtesy of Kurt Manufacturing, Inc

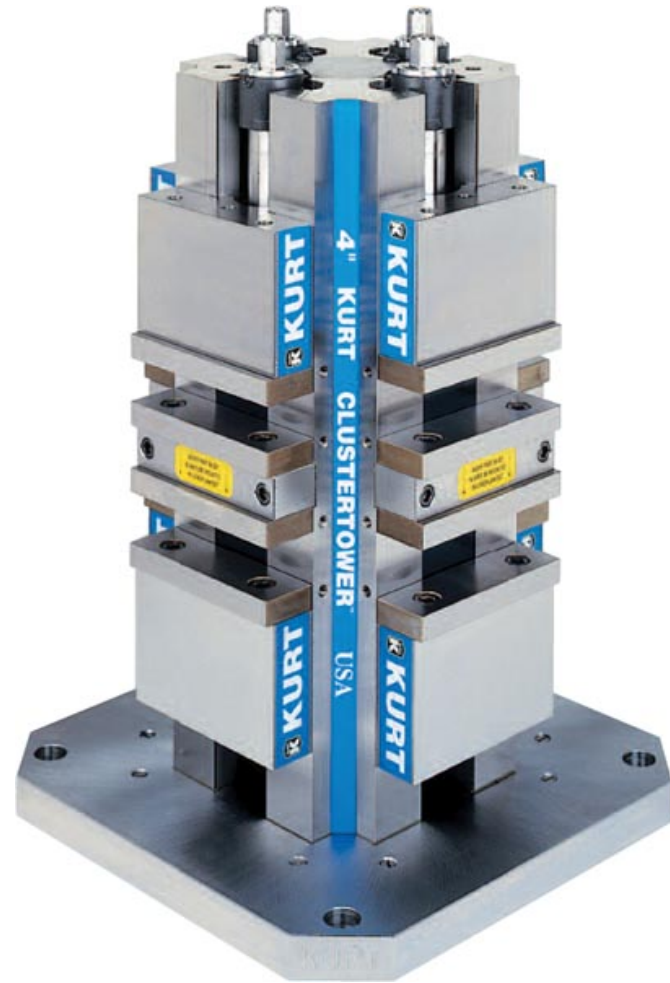

Courtesy of Kurt Manufacturing, Inc

The tombstone tower in (A) can be machined as needed for mounting work or other workholding devices. The tombstone tower in (B) has four integrated vises, one on each of the four sides of the tower.





Photo courtesy of Haas Automation, Inc

A custom fixture designed and built to hold an oddly shaped pump housing.



Richland College

DALLAS COUNTY COMMUNITY COLLEGE DISTRICT

# Process Planning

- Manufacturing process: all operations required to machine a part
- Process plan describes all steps in detail
  - Includes a description of each operation, the tools required, speed and feed data, workholding information, other notes and comments, and often a sketch depicting the part orientation

